

SPRINGLOADED PRESSURE REDUCING REGULATOR TBR(S)H8 THE MILLIBAR REGULATOR



MAIN FEATURES

- ss 316L body
- ptfе diaphragm
- balanced valve
- vacuum tight
- atex Ex II 2 GD
- adjustable from zero pressure
- easy to polish
- easy maintenance
- design according to EN 12516
- delivery according to PED

CHARACTERISTICS

| | |
|-------------------|---|
| Inlet pressure | : 0,1 - 6 bar, 0,1 -16 bar 16 bar design pressure |
| Outlet ranges | : 5 – 500 mbar 6 bar design pressure |
| Under pressure | : vacuum |
| Seat diameters: | |
| • TBR(S)H8 | : 8 mm |
| • TBR(S)H8 | : 5 mm |
| Seat leakage | : EN12266, rate a, p12 ANSI Class VI |
| Dependency ratio | : 1 : 3000 |
| Materials: | |
| • Body & Trim | : ss 316L |
| • Springhousing | : ss 316L |
| • Stem guide | : ptfе |
| • Valve housing | : ptfе |
| • Valve seat ring | : viton |
| • Diaphragm | : ptfе |
| Connections | : 1" bspp female 1" npt female flanges ansi 1" 150# rf flanges din DN25 PN16 tri-clamps 1" bsod |
| Weight: | |
| • screwed models | : 6,5 kg |
| • flanged models | : 8,5 kg |
| Temperature range | : -20°C to + 140°C * |

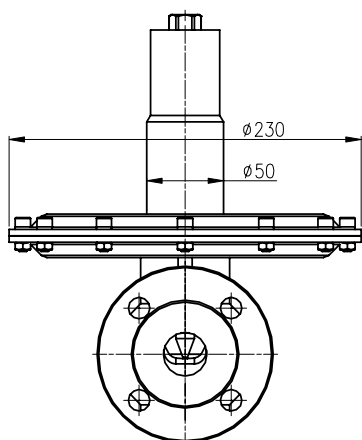
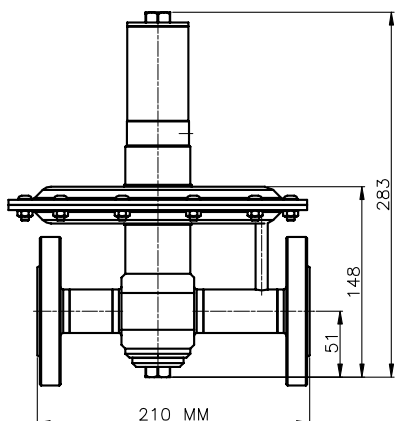

Do not use teflon tape or anaerobic sealing compounds on the bspp threads.

* Actual range depends on choice of seat- and seal material.

O-RINGS

Viton o-rings are standard.

Options:

- EPDM (compound FS-EPDM70-USP05) to FDA 21CFR, USP24 CL VI
- Kalrez (compound 6230) to FDA 21CFR, USP24 CL VI

CLEANING

This regulator is ultrasonically cleaned and degreased. Oxygen cleaning based on ASTM-G93 Level C / CGA 4.1 is optional.

INSTALLATION

Preferably in a vertical mode to allow draining.

From a control point of view there is little or no difference between horizontal or vertical mounting.

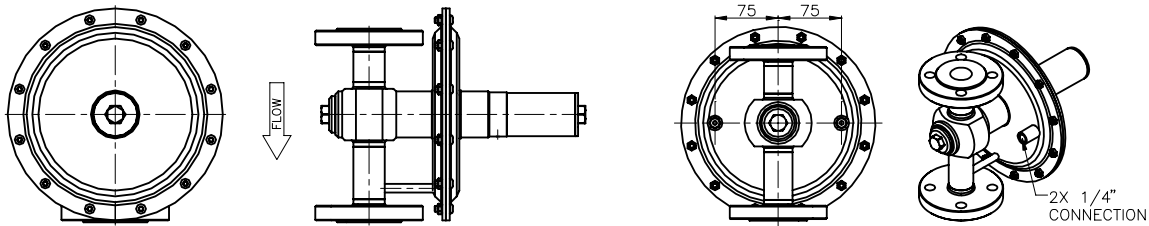

mounting mode (preferably)

gauge connections (option)

MAINTENANCE

- No need to remove LoB air from the system for maintenance / repair.
- No special tools required.

RECOMMENDATIONS

We recommend keeping the supply pressure level below 6 bar.

Set the supply blanketing regulator at 10 mbar outlet pressure and the vent valve at 30 mbar.

| | |
|-----------------|----------------|
| Supply pressure | : 0 - 6 bar |
| Pressure range | : 10 - 50 mbar |
| Mounting mode | : vertically |

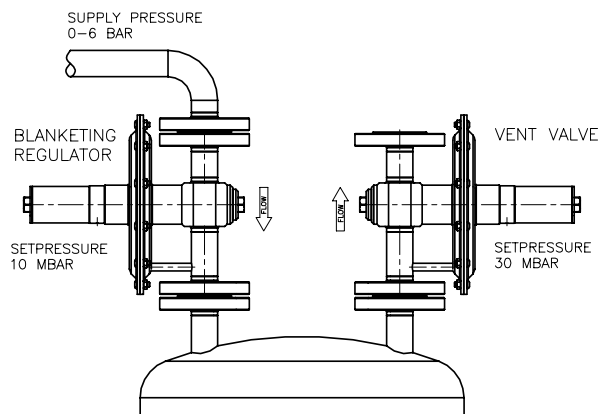

GENERAL INFORMATION

- Setpoint is the point where the regulator closes bubble tight.
- A tankblanketing regulator is not a substitute for a vacuum relief device.
- Failure of the tank blanketing regulator must be taken into account when considering possible causes of over-pressure in a tank.
- Dependency ratio 1: 3000 means that a change in inletpressure of 3bar (3000 mbar) will result in a change in outletpressure of 1 mbar.

DIMENSIONS

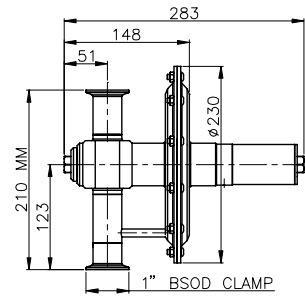
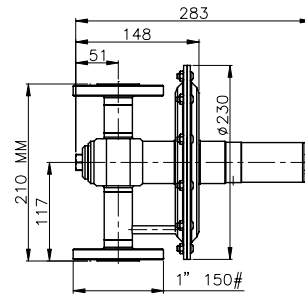
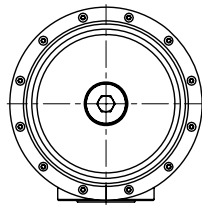
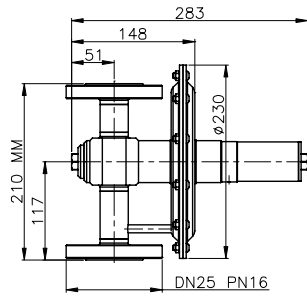

DN25 PN16 – EN 1092-1/Type 11 / B1

1" 150# - ANSI B16.5

1" BSOD CLAMP

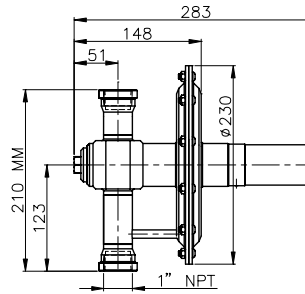
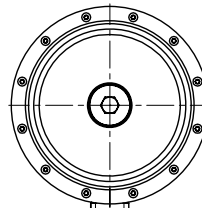
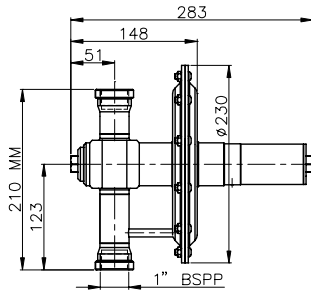

1" BSPP – ISO 228-1

1" NPT – ANSI B1.20.1

All dimensions are in millimeters.

FLOWTABLE – SEAT Ø8MM

| | | Airflow (Nm ³ /hr) | | | | | | | | | | |
|------------------------------|--|-------------------------------|-----|-----|-----|-----|----|----|----|-----|-----|-----|
| | | Inlet pressure (bar) | | | | | | | | | | |
| Outlet pressure range (mbar) | | 0.1 | 0.2 | 0.4 | 0.6 | 0.8 | 1 | 2 | 3 | 4 | 5 | 6 |
| 5 – 10 | | 4 | 8 | 16 | 24 | 32 | 40 | 65 | 85 | 105 | 125 | 145 |
| 10 – 50 | | " | " | " | " | " | " | " | " | " | " | " |
| 20 – 200 | | - | - | " | " | " | " | " | " | " | " | " |
| 50 – 500 | | - | - | - | - | - | " | " | " | " | " | " |

Note:
With inlet pressures less than 1 bar the outlet pressure must not exceed 50% of the inlet pressure in order to achieve the given flow.

FLOWTABLE – SEAT Ø5MM

| | | Airflow (Nm ³ /hr) | | | | | |
|------------------------------|--|-------------------------------|----|----|----|----|-----|
| | | Inlet pressure (bar) | | | | | |
| Outlet pressure range (mbar) | | 2 | 4 | 6 | 9 | 12 | 16 |
| 5 – 10 | | 16 | 32 | 48 | 70 | 90 | 120 |
| 10 – 50 | | " | " | " | " | " | " |
| 20 – 200 | | " | " | " | " | " | " |
| 50 – 500 | | " | " | " | " | " | " |

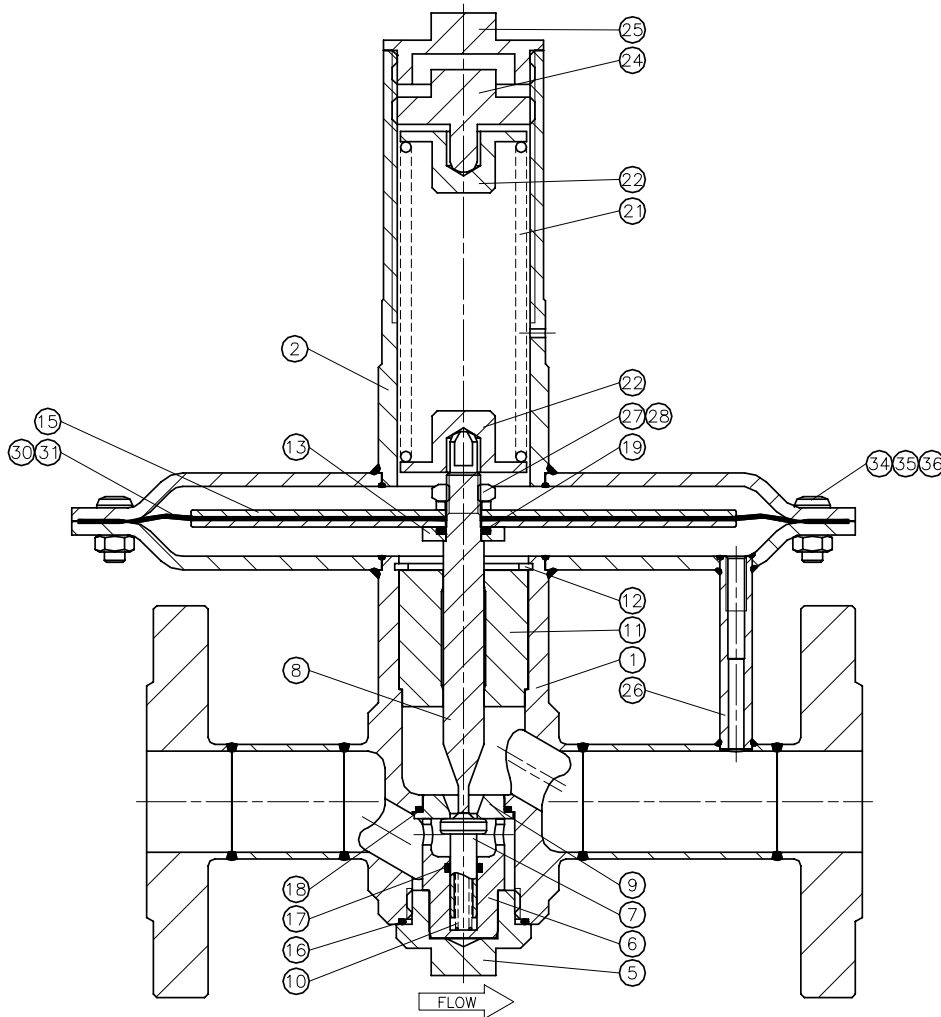

ORDERING INFORMATION

example: TBRSA8-02-3-VTV-FS

| TBR | | FA | -02 | -3 | -V | T | V | -FS |
|---|-------|--|--------------------|---|---|-----------------|---|--|
| serie | inlet | connection | material | outlet ranges | o-rings | dia-phragm | seat | options |
| TBR = 0,1-6 bar 8 mm seat TBRSH = 0,1-16 bar 5 mm seat | | B8 = 1" bspp N8 = 1" npt FA8 = 1" 150# ansi flanges FD8 = DN25 PN16 flanges TC8 = 1" bsod tri-clamps | 02 = ss316L | 1 = 5 – 10 mbar 2 = 10 – 50 mbar 3 = 20 –200 mbar 4 = 50 –500 mbar | V = viton Options: E = epdm K = kalrez | T = ptfe | V = viton Options: E = epdm K = kalrez | FS = factoryset & locked P4 = wetted parts polished 0,4 μ P8 = wetted parts polished 0,8 μ |

When placing an order please advise full process data.

Due to continuous development of our product range, we reserve the right to alter the dimensions and information contained in this leaflet as required. RHPs may suggest certain materials for certain applications. These suggestions are based on compatibility information provided by material suppliers or on previous experience. However, RHPs does not guarantee the material to be compatible with a specific media, this will be the sole responsibility of the user.